

# 1003A-CB\*\*\*-CBCG

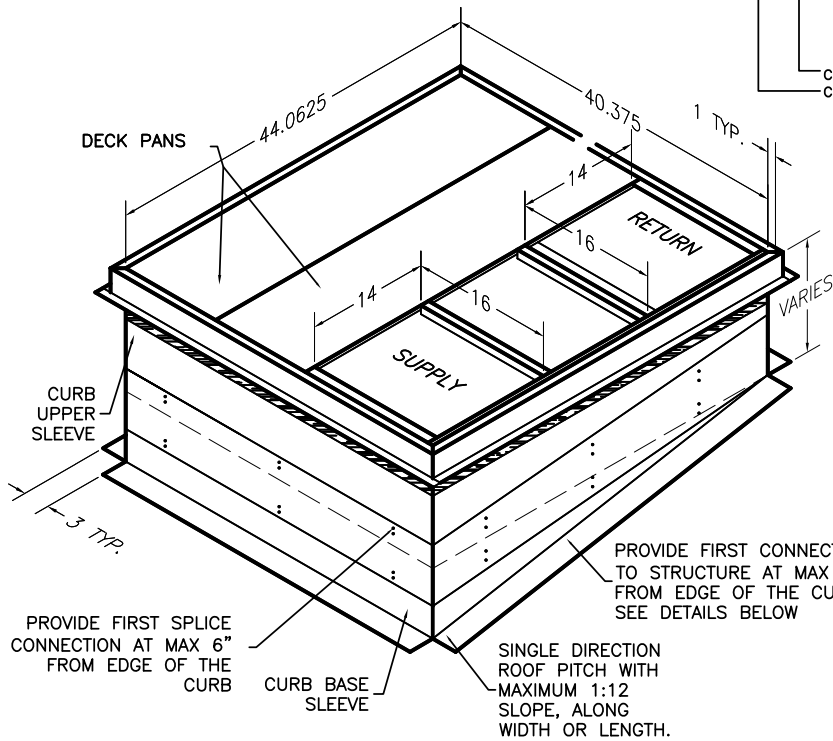

**CURB CONSTRUCTION**  
 1) WELDED  
 2) FINGERLOCK  
 -ALL WELDING CONSTRUCTION CERTIFIED TO ANSI/AWS D1.3 STRUCTURAL WELDING CODE-SHEET METAL  
 -SELF-DRILLING SCREW SHALL MEET ASTM C1513 SPECIFICATION AND INSTALLED PER AISI-S100  
 -NO GAP IS ALLOWED BETWEEN TWO METAL SHEET SURFACES WHERE SHEET METAL SCREW IS CONNECTED

ALL WORK SHALL CONFORM TO THE STANDARD OF 2015 INTERNATIONAL BUILDING CODE & 2016 CALIFORNIA BUILDING CODE.

**SEISMIC DESIGN CRITERIA**  
 -SDS = 1.5      ap = 2.5  
 -I = 1.5          Rp = 6.0

**WIND DESIGN CRITERIA**  
 -MAX 60 FT TALL BUILDING  
 -EXPOSURE C  
 -130 MPH, 3 SECOND GUST WIND

**NOTE:**  
 INSTALLER TO VERIFY WITH A LICENSED STRUCTURAL ENGINEER IN THE CORRESPONDING STATE THE ADEQUACY OF THE STRUCTURE FOR LOADS IMPOSED BY THE UNIT AND THE CURB IN ADDITION TO ALL OTHER LOADS.  
 -INSTALLER TO VERIFY WITH A LICENSED STRUCTURAL ENGINEER IN THE CORRESPONDING STATE THAT THE SEISMIC AND WIND DESIGN CRITERIA NOTED ON THIS DRAWING ARE ADEQUATE FOR THE SITE SPECIFIC VALUES. OTHERWISE, CONTACT CANNON FABRICATION FOR A SITE SPECIFIC ANALYSIS AND DRAWINGS.

**CURB AND UNIT INFORMATION**  
 16 GAUGE GALVANIZED STEEL CURB  
 1003A-CB11\*-CBCG    11"    164 LBS.  
 1003A-CB14\*-CBCG    14"    184 LBS.

MAX UNIT OPERATING WEIGHT 450 LBS  
 CGY FROM CORNER = 22.5" PARALLEL TO LENGTH  
 CGH FROM BOTTOM OF UNIT = 17.6"

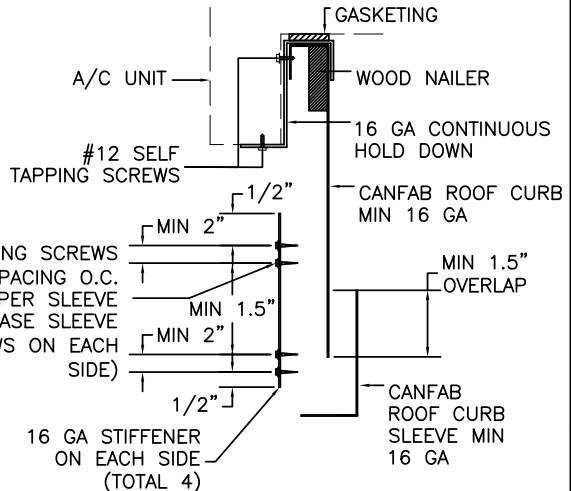

#14 SELF TAPPING SCREWS @ 15" MAX SPACING O.C.  
 2 ROWS ON UPPER SLEEVE  
 2 ROWS ON BASE SLEEVE  
 (TOTAL 4 ROWS ON EACH SIDE)

## ANCHORAGE DETAILS TO ROOF:

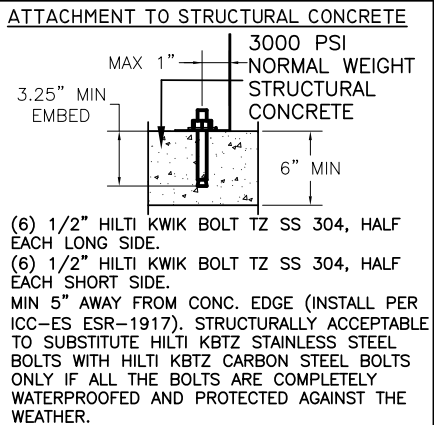
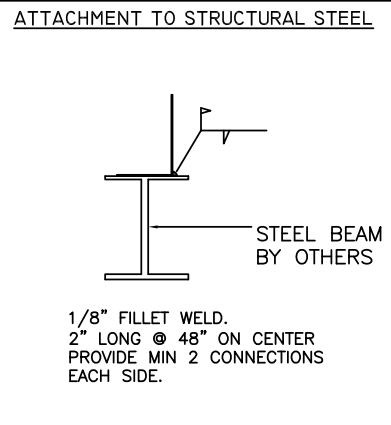
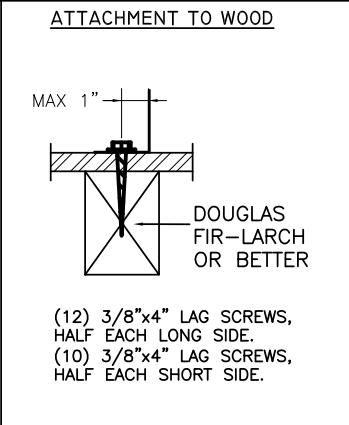
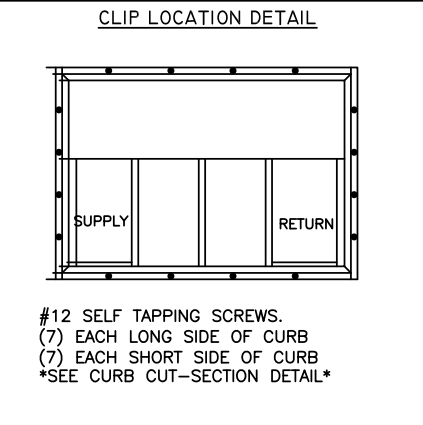

STRUCTURAL REVIEW BY:

**MARTIN & associates**

JOHN A. MARTIN AND ASSOCIATES  
 Structural Engineers  
 950 South Grand Ave., 4th Floor  
 Los Angeles, California 90015  
 Phone (213) 483 6490  
 Fax (213) 483 3084  
 Job No: 13001



182 GRANITE STREET, SUITE 101, CORONA, CA 92879  
 PHONE: (951)278-1830 FAX: (951)278-8444 www.canfab.com canfab@canfab.com

FOR: CARRIER	PROJECT:
PART NO: 1003A-CB***-CBCG	DISTRIBUTOR:
ENGINEER: LD	DATE: 7.30.18
DRAWING NO: 1003ACA.DWG	DATE: / /
APPROVED BY:	

WELDED ROOF CURB ASSEMBLY

- (A) REMOVE CONTENTS (WELDED UPPER CURB, WELDED LOWER CURB SLEEVE, 2-STIFFENERS, SCREW PACKAGE & GASKETING) FROM SHIPPING PACKAGE. SLIDE ROOF CURB OVER BASE SLEEVE. ADJUST THE PITCH OF THE ROOF CURB TO DESIRED ANGLE.
- (B) INSTALL GASKET AROUND THE TOP FLANGE OF THE ROOF CURB. YOU WILL NEED TO DOUBLE UP THE GASKET AROUND THE SUPPLY AND RETURN OPENINGS.
- (C) USING THE SCREWS AND PRE-PUNCHED HOLES PROVIDED. INSTALL THE STIFFENERS ACCORDING TO THE DIMENSIONS ON THE SUBMITTAL. BE SURE TO POSITION STIFFENER TO ALLOW A MINIMUM OVERLAP OF 1.5" BETWEEN THE UPPER AND LOWER CURB SLEEVES.

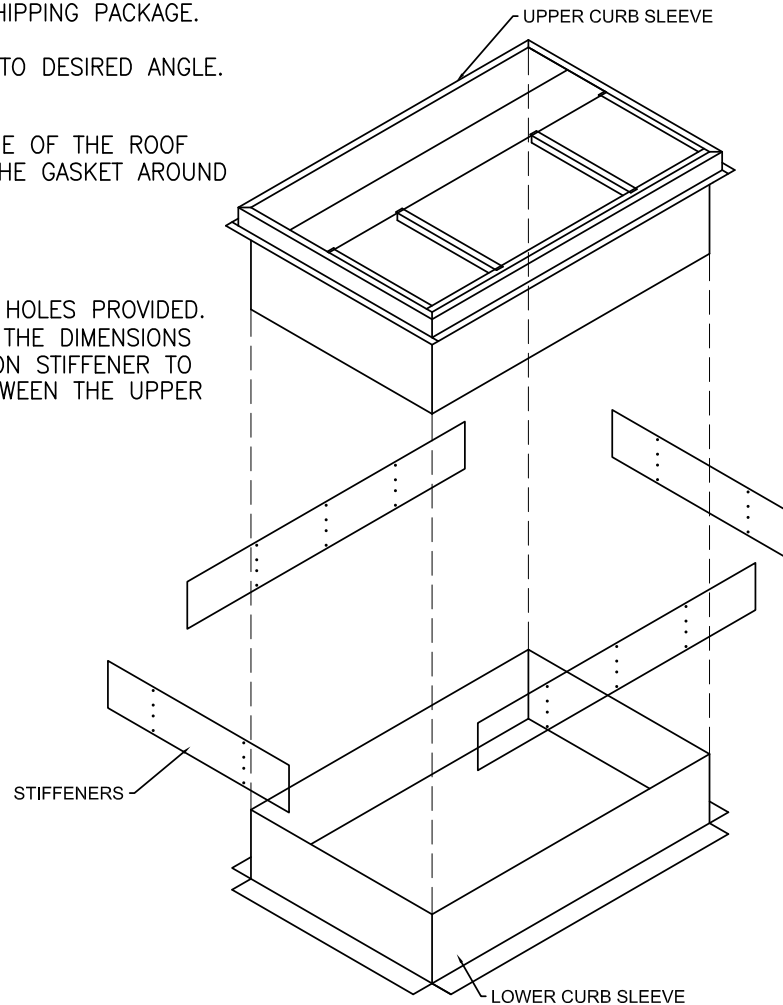

1003A-CB11W/14W-CBCG	
PART NUMBER	QTY
1003A-CB**W-CBCG-01A	2
1003A-CB**W-CBCG-01B	2
1003A-CB**W-CBCG-02A	2
1003A-CB**W-CBCG-02B	2
1003A-CB**W-CBCG-03A	2
1003A-CB**W-CBCG-03B	2
1003A-CB**W-CBCG-03C	1
1003A-CB**W-CBCG-04	2
1003A-CB**W-CBCG-05A	2
1003A-CB**W-CBCG-05B	2
1312-WOOD	44.0625" (SIDE)
1312-WOOD	41.875" (END)
ASN10018GS	4
14135GASKET	1 ROLL
1034TEK	72



182 GRANITE STREET, SUITE 101, CORONA, CA 92879  
 PHONE: (951)278-1830 FAX: (951)278-8444 www.canfab.com canfab@canfab.com

FOR: CARRIER ADJUSTABLE PITCH CURB  
 FIELD INSTALLATION INSTRUCTIONS

PART NO: 1003A-CB\*\*W-CBCG

PROJECT:

ENGINEER: LD

DISTRIBUTOR:

DRAWING NO: 1003ACA.DWG

DATE: 8.20.18

APPROVED BY:

DATE: / /



CANNON FABRICATION INC

182 GRANITE STREET, SUITE 101, CORONA, CA 92879

PHONE: (951)278-1830 FAX: (951)278-8444 www.canfab.com canfab@canfab.com

FOR: 1003A-CB\*\*W-CBCG  
EXPLODED VIEW

PART NO: 1003A-CB\*\*W-CBCG

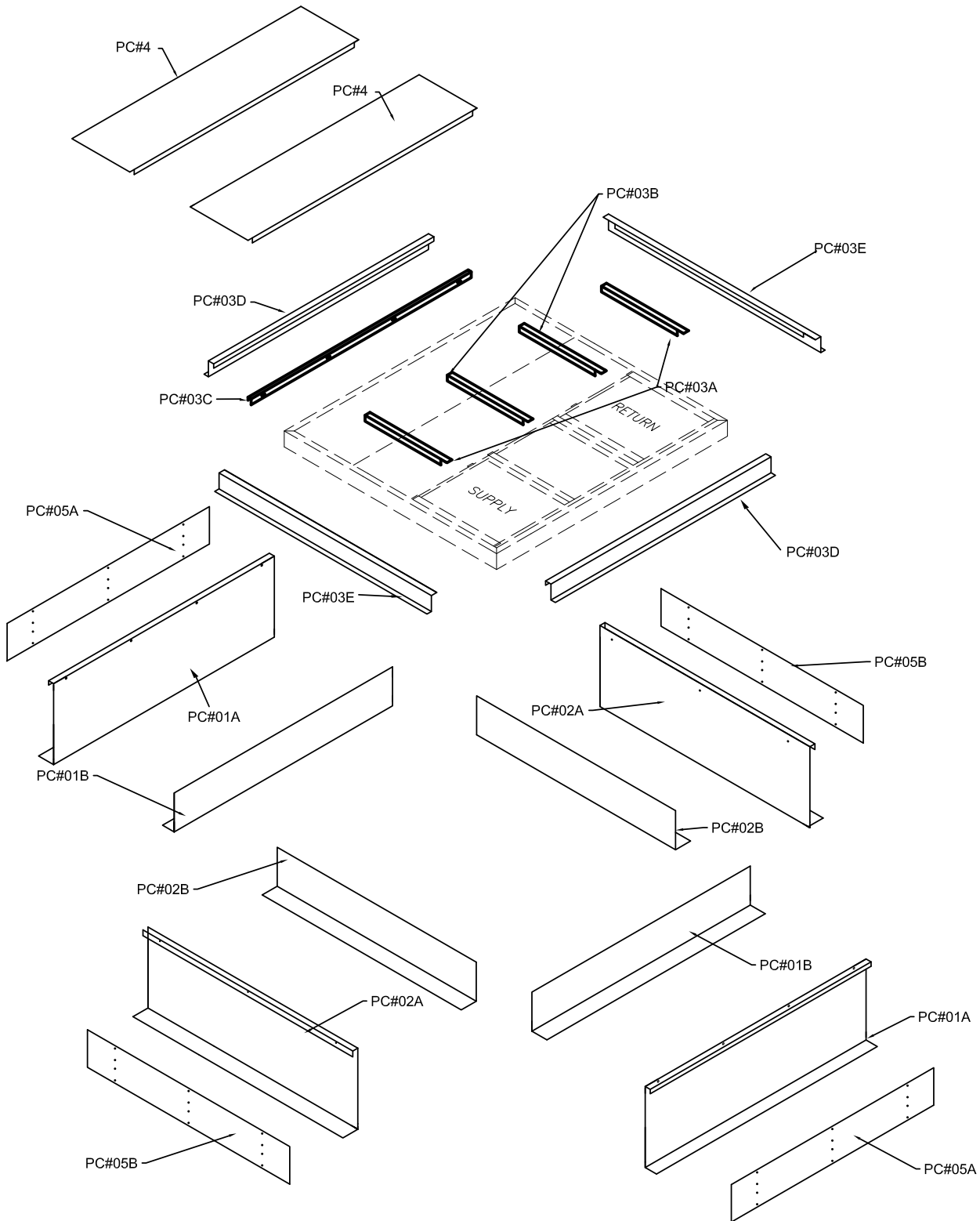

PROJECT:

DATE: 8.16.18

ENGINEER: LD

DISTRIBUTOR:

DRAWING NUMBER: 1003ACA.DWG





182 GRANITE STREET, SUITE 101, CORONA, CA 92879

PHONE: (951)278-1830 FAX: (951)278-8444 www.canfab.com canfab@canfab.com

FOR: 1003A-CB\*\*W-CBCG  
PARTS LIST

PART NO: 1003A-CB\*\*W-CBCG

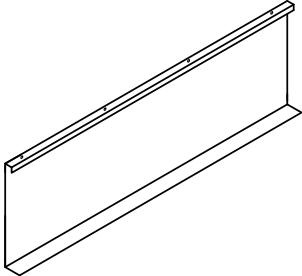
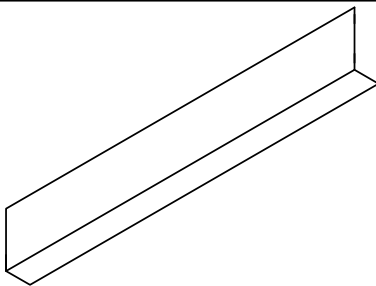
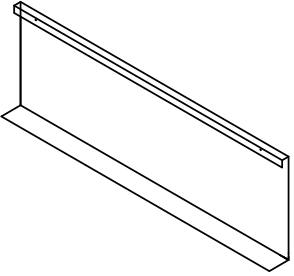
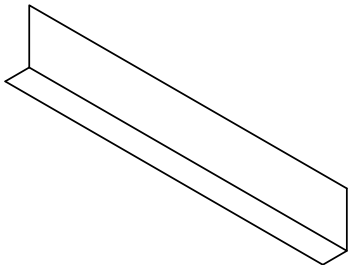
# 1003A-CB\*\*W-CBCG-PARTS LIST

PART #	QTY	
1003A-CB**W-CBCG-01A	2	
1003A-CB**W-CBCG-01B	2	
1003A-CB**W-CBCG-02A	2	
1003A-CB**W-CBCG-02B	2	
1003A-CB**W-CBCG-03A	2	

PROJECT:

DATE: 8.20.18

ENGINEER: LD

DISTRIBUTOR:

DRAWING NUMBER: 1003ACA.DWG



182 GRANITE STREET, SUITE 101, CORONA, CA 92879

PHONE: (951)278-1830 FAX: (951)278-8444 www.canfab.com canfab@canfab.com

FOR: 1003A-CB\*\*W-CBCG  
PARTS LIST

PART NO: 1003A-CB\*\*W-CBCG

# 1003A-CB\*\*W-CBCG-PARTS LIST

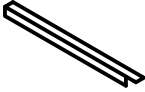
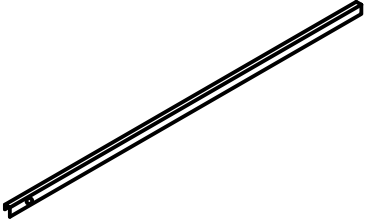
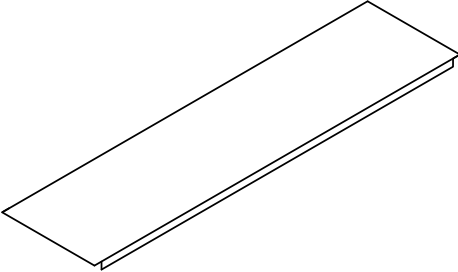
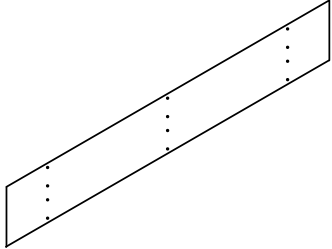
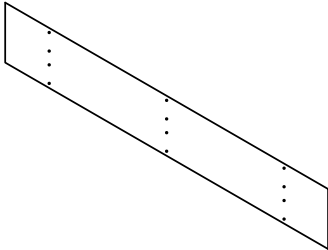
PART #	QTY	
1003A-CB**W-CBCG-03B	2	
1003A-CB**W-CBCG-03C	1	
1003A-CB**W-CBCG-04	2	
1003A-CB**W-CBCG-05A	2	
1003A-CB**W-CBCG-05B	2	

PROJECT:

DATE: 8.20.18

ENGINEER: LD

DISTRIBUTOR:

DRAWING NUMBER: 1003ACA.DWG